

"TRADER" SERVICE SHEET
747

BARKER 88

AC SUPERHET

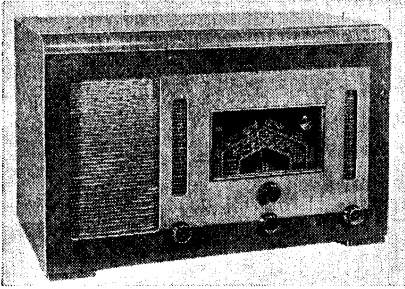

The Barker 88 Table Model.

THE Barker 88 is a "Stores" receiver, for which there is a widespread demand for technical data. It employs six receiving valves, a rectifier and a cathode ray tuning indicator, and has three wavebands. The SW range is 14-50m., and the set operates from AC mains of 200-250v. The radiogram and auto-radiogram versions employ chassis which, except for

pick-up switching, are identical with those in the table model, from a sample of which this Service Sheet was prepared. Release date and original prices: 1938; Table model, £6 19s. 6d.; RG, £13 2s. 6d.; RGA, £17 6s. 6d.

CIRCUIT DESCRIPTION

Aerial input is developed across **C1**, **L1** and **C2** which form a potential divider, shunted by **R1**. On SW, where the impedance of **C2** is negligible, signal is developed mainly across **L1** and passed to single-tuned circuit **L2**, **C25**, while **C1** is a series coupling capacitor.

On MW and LW, where the impedance of **L1** is negligible, **C1** and **C2** form a potential divider to provide bottom coupling from **C2**, which is common with aerial coupling and tuning circuits, to single-tuned circuits **L3**, **C25** (MW) and **L4**, **C25** (LW).

First valve (**V1**, **6K8G**) is a triode hexode operating as frequency changer with electron coupling. Triode oscillator grid coils **L5** (SW), **L6** (MW) and **L7** (LW) are tuned by **C26**. Parallel trimming by **C27** (MW) and **C28** (LW); series tracking by fixed capacitors **C4** (SW), **C5**

(MW) and **C6** (LW), tracking adjustments being made by altering the inductance values of the coils. This is achieved by a "loop" adjustment on **L5**, and by adjustable dust-iron cores on **L6** and **L7**.

Reaction coupling from anode, via coupling capacitor **C7**, is effected by **L8** on SW, and by reaction windings formed by extensions of the tuning coil windings on MW and LW, a tapping on each coil being connected to chassis.

Second valve (**V2**, **6U7G**) is a variable-mu RF pentode operating as intermediate frequency amplifier with tuned primary, tuned-secondary transformer input coupling **C29**, **L9**, **L10**, **C30** and single-tuned output coupling **L11**, **C10**. The transformer has the usual pre-set capacitative trimmer adjustments, but the output coupling has an adjustable dust-iron core to **L11**.

Intermediate frequency 465 kc/s.

Diode second detector is part of double diode triode valve (**V3**, **6R7G**), paralleled from a tapping on **L11** via **C12**. Audio frequency component in rectified output is developed across load resistors **R8**, **R9** which form a step-down coupling

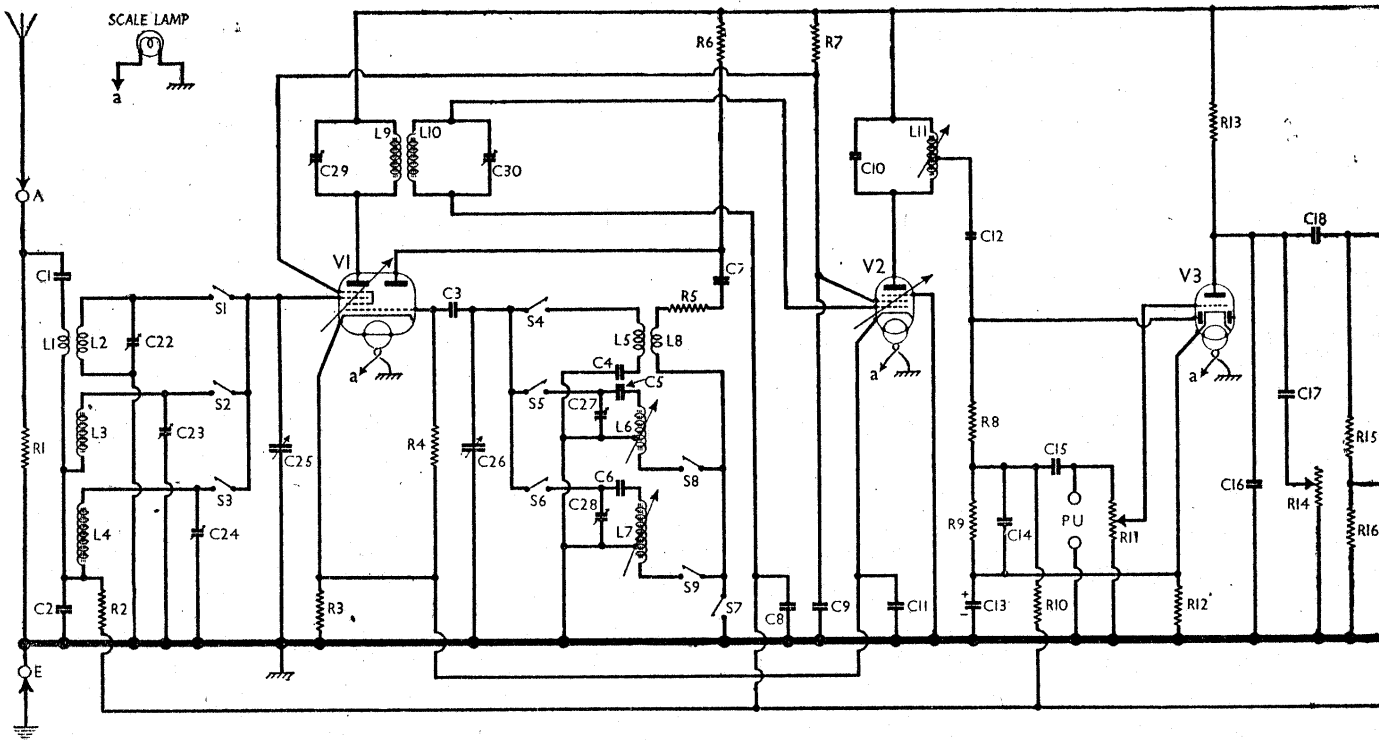

Circuit diagram of the Barker 88 3-band AC superhet as used in all three models. A diagram of the speaker plug, as seen from the free ends of the pins, is inset in the top right-hand corner of the diagram. The place of the second IF transformer is taken by a single tuned circuit **L11**, **C10**. **V1** and **V2** have a common cathode circuit. A phase-reversing valve **V4** feeds one side of the push-pull output stage from the step-down coupling **R15**, **R16**. An alternative method of driving the output stage is described overleaf

to limit the AF output, the signal voltage across **R9** being passed via AF coupling capacitor **C15** and manual volume control **R11** to CG of triode section, which operates as AF amplifier. The second diode is unused.

IF filtering by **R8**, **C14** in diode circuit, and by **C16** in triode anode circuit. Provision for connection of gramophone pick-up across **R11**. Variable tone control by **C17**, **R14**.

DC potential appearing across **R9** is tapped off and fed back through decoupling circuits as GB to FC and IF valves, giving automatic volume control. The AVC line potential is also used as control voltage for cathode ray tuning indicator (**T.I.**, **6G5**).

The AVC line receives a positive bias with respect to chassis from the cathode potential of **V3**, to which **R9** is returned, but this is offset for **V1** and **V2** by their fixed common bias resistor **R3**.

Resistance-capacitance coupling by **R13**, **C18** and **R15**, **R16** between **V3** triode and one side (**V5**) of push-pull output stage comprising two pentodes (**V5**, **V6**, **6F6G's**) which operate with a common GB resistor **R22**. The second valve of the pair (**V6**) is driven by a phase-reversing valve (**V4**, **6C5G**) whose control grid is fed from the junction of **R15** and **R16**, giving a step-down coupling to compensate for the gain of the valve. Resistance-capacitance coupling between **V4** and **V6** is provided by **R17**, **C19** and **R19**.

HT current is supplied by full-wave

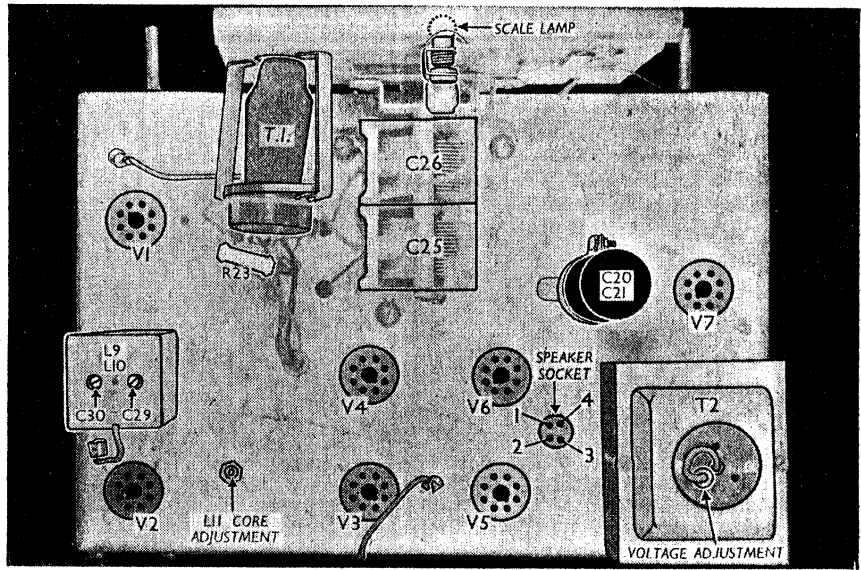

Plan view of the chassis. A special screen for **V2** is held by the two screws seen on the rear edge of the chassis near **V2** holder.

rectifying valve (**V7**, **5Z4G**). Smoothing by speaker field **L14** and electrolytic capacitors **C20**, **C21**.

COMPONENTS AND VALUES

RESISTORS		Values (ohms)
R1	Aerial circuit shunt ...	40,000
R2	V1 hex. CG decoupling ...	150,000
R3	V1, V2 fixed GB resistor ...	140
R4	V1 osc. CG resistor ...	50,000
R5	Osc. reaction damping ...	140
R6	V1 osc. anode HT feed ...	30,000
R7	V1, V2 SG's HT feed ...	30,000
R8	IF stopper ...	150,000
R9	V8 diode load ...	250,000
R10	AVC line decoupling ...	3,000,000
R11	Manual volume control ...	500,000
R12	V3 triode GB resistor ...	900
R13	V3 triode anode load ...	50,000
R14	Variable tone control ...	50,000
R15	V5 CG resistor; step-down coupling to V4...	250,000
R16		30,000
R17	V4 anode load ...	40,000
R18	V4 GB resistor ...	800
R19	V6 GB resistor ...	250,000
R20	V6 SG HT feed ...	100
R21	V5 SG HT feed ...	100
R22	V5, V6 GB resistor ...	220
R23	T.I. anode HT feed ...	1,000,000

CAPACITORS		Values (μF)
C1	Aerial MW and LW coupling pot. divider ...	0.0006
C2		0.0024
C3	V1 osc. CG capacitor ...	0.0001
C4	Osc. circ. SW tracker ...	0.006
C5	Osc. circ. MW tracker ...	0.00035
C6	Osc. circ. LW tracker ...	0.00015
C7	V1 osc. anode coupling ...	0.02
C8	AVC line decoupling ...	0.02
C9	V1, V2 SG decoupling ...	0.1
C10	V2 anode tuning ...	0.00005
C11	V1, V2 cathodes by-pass ...	0.1
C12	Coupling to V3 diode ...	0.00005
C13*	V3 cathode by-pass ...	25.0
C14	IF by-pass ...	0.0004
C15	AF coupling to V3 triode ...	0.02
C16	IF by-pass ...	0.0006
C17	Part of tone control ...	0.02
C18	AF coupling to V5 ...	0.02
C19	V4 to V6 AF coupling ...	0.02
C20*	HT smoothing capacitors	16.0
C21*		8.0
C22†	Aerial circ. SW trimmer ...	—
C23†	Aerial circ. MW trimmer ...	—
C24†	Aerial circ. LW trimmer ...	—
C25†	Aerial circuit tuning ...	—
C26†	Oscillator circuit tuning ...	—
C27†	Osc. circ. MW trimmer ...	—
C28†	Osc. circ. LW trimmer ...	—
C29†	IF trans. pri. tuning ...	—
C30†	IF trans. sec. tuning ...	—

* Electrolytic. † Variable. ‡ Pre-set.

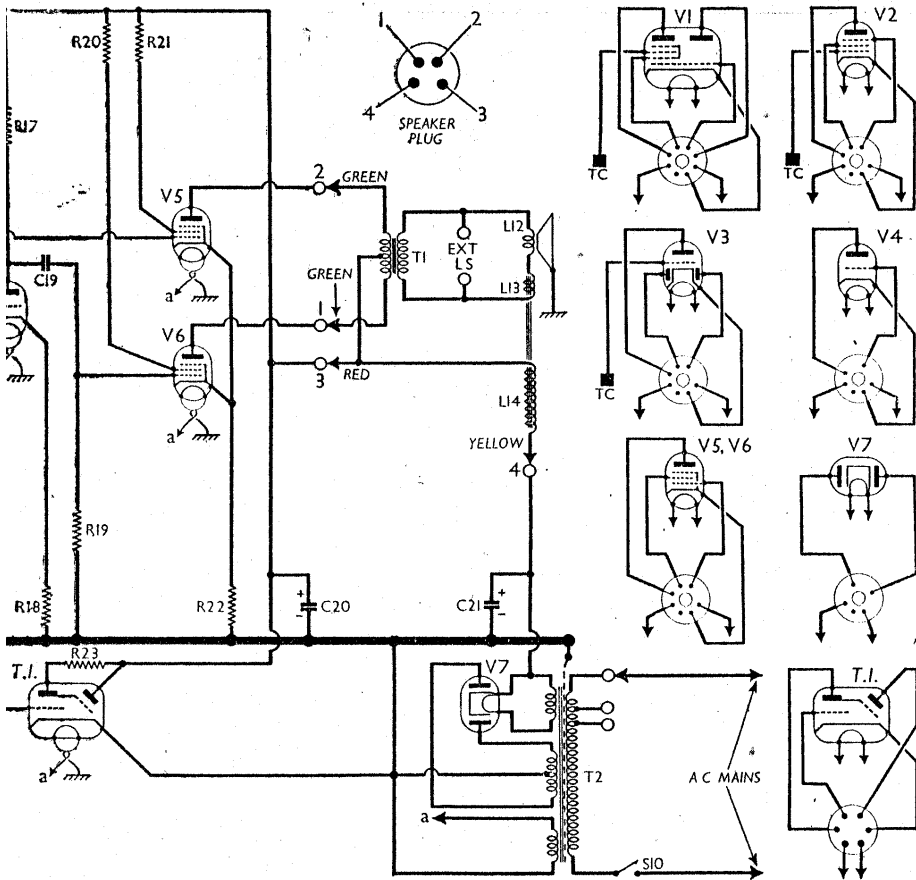

OTHER COMPONENTS		Approx. Values (ohms)	
L1	Aerial SW coupling coil ...	6.0	
L2	Aerial SW tuning coil ...	Very low	
L3	Aerial MW tuning coil ...	4.0	
L4	Aerial LW tuning coil ...	10.0	
L5	Osc. SW tuning coil ...	Very low	
L6	Osc. circ. MW coil ...	2.8	
L7	Osc. circ. LW coil ...	7.0	
L8	Osc. SW reaction coil ...	7.7	
L9	} IF trans { Pri. ...	2.0	
L10		Sec. ...	2.0
L11	V2 anode IF coil ...	5.5	
L12	Speaker speech coil ...	1.5	
L13	Hum neutralising coil ...	0.3	
L14	Speaker field coil ...	650.0	
T1	Speaker input trans. { Pri. ...	450.0	
		Sec. ...	0.15
T2	Mains { Heater sec. ...	16.0	
		Rect. heat. sec. ...	0.05
		HT sec. total ...	0.1
S1-S9	Waveband switches ...	240.0	
S10	Mains switch, ganged R14	—	

VALVE ANALYSIS

Valve voltages and currents given in the table below are those measured in our receiver when it was operating on mains of 240 V, using the 250 V tapping on the mains transformer.

The receiver was tuned to the lowest wavelength on the MW band, and the volume control was at maximum, but there was no signal input.

Voltages were measured on 400 V scale of a model 7 Avometer, chassis being the negative connection.

Valve	Anode Voltage (V)	Anode Current (mA)	Screen Voltage (V)	Screen Current (mA)
V1 6K8G	235	1.0	77	3.5
	Oscillator			
V2 6U7G	100	3.8	77	1.0
	235	4.2		
V3 6R7G	70	2.6	—	—
V4 6C5G	80	3.5	—	—
V5 6F6G	225	30.0	230	7.0
V6 6F6G	225	30.0	230	7.0
V7 5Z4G	325†	—	—	—
T.I. 6G5	15	0.5	—	—
	Target			
	235	2.0	—	—

† Each anode, AC.

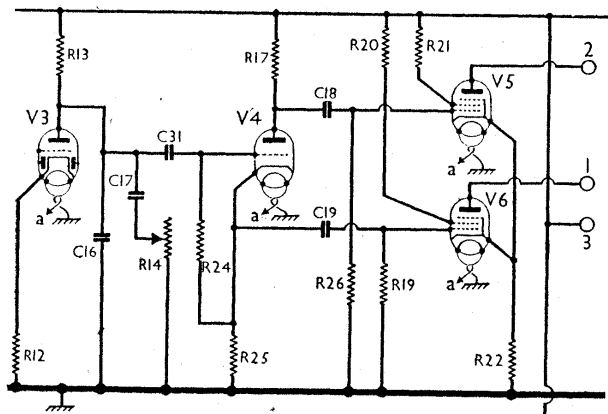

The AF section of the circuit diagram overleaf redrawn to show the alternative output circuit used in some chassis. The circles numbered 1, 2 and 3 are three of the speaker sockets. R24, R25, R26 and C31 are additional components.

DISMANTLING THE SET

The cabinet is fitted with a detachable bottom cover, upon removal of which (six countersunk head wood screws) access may be gained to most of the components beneath the chassis.

Removing Chassis.—Remove the four control knobs (recessed grub screws) from the front of the cabinet;

withdraw the speaker plug from its socket on the chassis deck; free the speaker earthing lead, soldered to the metal scale assembly, from the neighbouring speaker fixing screw; remove the four bolts (with two specially shaped rubber washers and one steel washer each) holding the chassis to the bottom of the cabinet, when the chassis may be withdrawn.

When replacing, note that the two rubber washers on each chassis fixing bolt go one either side of the base of the cabinet, where recesses are cut for them, the collar on each washer facing its fellow. The steel washer goes directly beneath the bolt head.

Removing Speaker.—Withdraw the connecting plug from its socket on the chassis deck;

free the speaker leads from the cleat in the rear corner of the cabinet;

remove the nuts from the four bolts holding the speaker to the sub-baffle.

When replacing, the transformer should point to the bottom right-hand corner of the cabinet, and if the leads have been unsoldered they should be connected as follows, numbering the tags on the transformer from left to right when seen from the rear:—

- 1, yellow; 2, green; 3, no connection; 4, green; 5, red.

GENERAL NOTES

Switches.—S1-S9 are the waveband switches, ganged in a single rotary unit beneath the chassis. The unit is indicated in our under-chassis view, and shown in detail in the diagram in col. 3 on this page, where it is drawn as seen when viewed from the rear of the underside of the chassis. B indicates blank tags, and Be a bearer tag.

The table (col. 3) gives the switch positions for the three control settings, starting from the fully anti-clockwise (SW) position of the control knob. A dash indicates open, and C, closed.

S10 is the QMB mains switch, ganged with the tone control R14.

screened unit on the chassis deck, but the single-tuned IF unit L11, C10 is in an unscreened unit beneath the deck.

Switch Table and Diagram

Switch	SW	MW	LW
S1	—	—	—
S2	—	—	—
S3	—	C	—
S4	—	—	—
S5	—	C	—
S6	—	—	—
S7	—	C	—
S8	—	C	—
S9	—	—	C

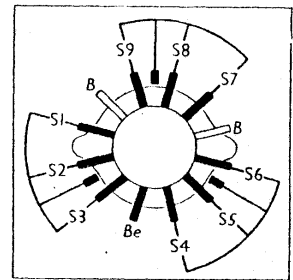

Diagram of the waveband switch unit, drawn as seen when viewed from the rear of the underside of the chassis. B indicates a blank tag, and Be indicates a bearer. Above the diagram is the associated switch table.

Trimmers.—The five RF and oscillator trimmers C22-C24 and C27, C28 are arranged in a row beneath the chassis deck, but they are not visible in our under-chassis view, as they are hidden by the coil assembly. Their position is indicated there approximately by an arrow.

Their adjustment heads are reached from the front of the chassis, and to facilitate alignment and to indicate the trimmer positions clearly the adjustments are shown in the drawing in col. 5, where they are viewed as seen from the front of the chassis when it is standing on its base. The L6, L7 core adjustments are just below them.

Scale Lamp.—This is a standard type of lamp with a clear spherical bulb and an MES base. 6.2 V, 0.3 A would be a suitable rating.

External Speaker.—Two screw terminals are provided on the connecting panel on the speaker input transformer for the connection of a low impedance (about 2-3Ω) external speaker.

Capacitors C20, C21.—These are two electrolytics in a single tubular metal container mounted on the chassis deck, the container forming the common negative connection. The red-spotted tag is the positive connection of C21 (8 μF) and the plain tag that of C20 (16 μF). The unit is a surge-limiting type rated at 450 V working.

An alternative type has 16 μF (C21) and 24 μF (C20) sections, while late models may be housed in a rectangular cardboard carton.

Capacitor C5.—A prevalent and elusive fault has been found to be due to a breakdown of C5. The symptoms are sudden

Coils.—The RF and oscillator tuning coils L1-L8 are wound on four tubes arranged symmetrically in an unscreened assembly around the waveband switch unit. Both MW coils are on one long tube, and both LW coils are on the other; the two SW coils are in separate units with their coupling windings.

The IF transformer L9, L10 is in a

Under-chassis view. The RF and oscillator coils and trimmers are grouped round the wave-band switch unit S1-S9, and the whole assembly may be removed, together with its mounting plate, as a single assembly upon removing the fixing screws and unsoldering the connecting leads. The switch unit is shown in detail in the diagram in col. 3 opposite. The positions of the trimmers C22-C24 and C27, C28 are shown in the sketch, in col. 5 below.

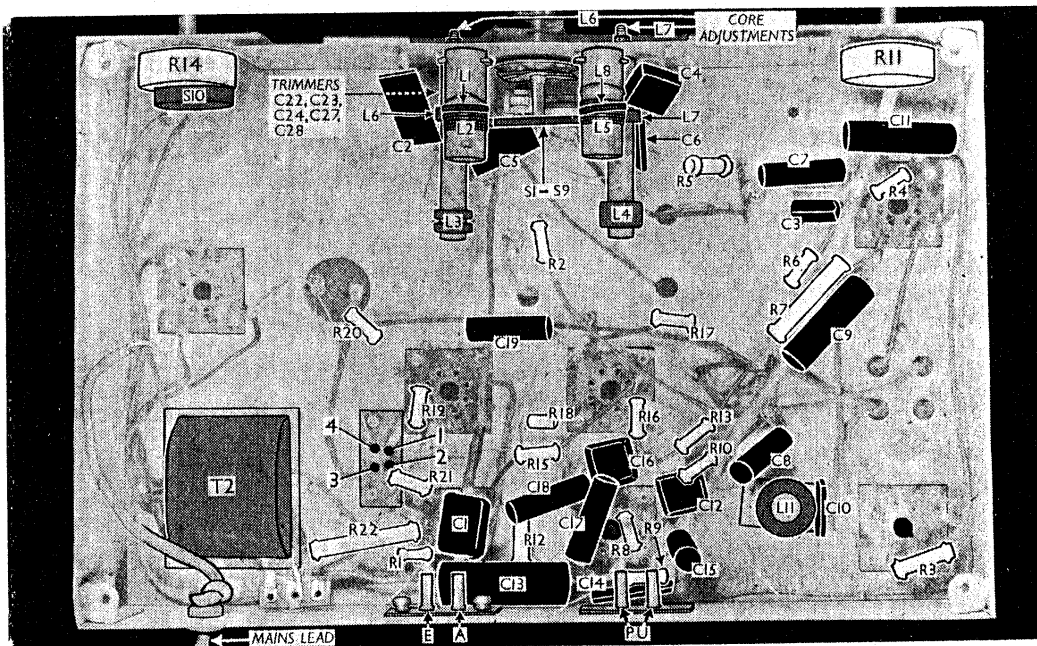

cessation of signals over a large area at one end of the band, signals reappearing when set is tuned to the other end of the band. Replacement of C5 effects a cure, but this necessitates subsequent MW realignment.

V2 Screen.—An angle-shaped piece of metal which is screwed to the rear member of the chassis forms a screen for V2, and without it the set is usually unstable. The screen is held by the two screws seen in our plan view, and has a hole in its top for the valve neck to pass through. The screen must be removed before the valve can be withdrawn from its socket.

Alternative Valves.—V5 and V6 may be 6V6G's, 6A6G's, or Marconi/Osram KT61's or KT63's. Where 6V6G's are used, R22 becomes 180Ω.

Other Marconi/Osram valves that may be used are X65 (V1), KT6W63 (V2), DL63 (V3), L63 (V4), U50 (V7) and Y63 (tuning indicator). U50 is directly heated.

Chassis Divergencies.—The normally unused trimmer position between C24 and C27 may in some cases be occupied by a second oscillator LW trimmer connected in parallel with C28.

As mentioned previously, the values of C20 and C21 may be different from those quoted in our tables; they may also be housed in a rectangular cardboard container beneath the chassis, instead of the tubular metal one.

C1 may vary considerably, but it should be borne in mind that variations here have a marked effect on aerial coupling. If C1 is too large, V1 may be overloaded. R4 may be between 50,000 Ω and 100,000 Ω and R20, R21 may vary between 80 Ω and 100 Ω.

Alternative Output Stage.—Although all models employ a resistance-capacitance coupled output stage, this may be of the

kind shown in the diagram in cols 1 and 2 opposite instead of as shown in our circuit diagram overleaf.

The alternative arrangement consists mainly of rearranged connections, although a few component values are altered. In the revised diagram, those components which perform the same functions as in the original circuit overleaf and retain the same values are given the

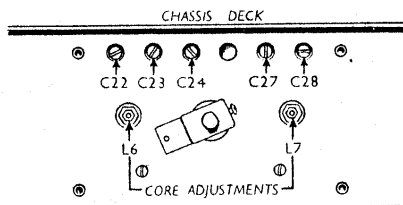

Sketch showing the positions of the five RF and oscillator trimmers and the oscillator coil core adjustments. They are drawn as seen from the front of the chassis. The vacant hole may sometimes be occupied by second trimmer in parallel with C28.

same numbers, while C31, R24, R25 and R26 are added to replace R15, R16 and R18, which are omitted.

Phase-splitting is achieved now by dividing V4 anode load into two equal parts, R17 and R25, and inserting one of them in the cathode circuit. V5 is then driven from V4 anode, and V6 from V4 cathode. V4 is coupled in the normal manner to V3 triode anode, but its control grid resistor R24 is returned to the cathode.

The values of the additional components are: C91, 0.02 μF; R24, 1,000,000 Ω; R25, 40,000 Ω; R26, 250,000 Ω.

CIRCUIT ALIGNMENT

IF Stages.—Remove top cap connector from V1, and connect signal generator leads to control grid (top cap) of the valve and chassis. A 500,000 Ω resistor should be shunted across the signal generator leads.

Feed in a 465 kc/s (645.16 m) signal, turn the volume control to maximum, and adjust L11 (screw on chassis deck) for maximum output. Then adjust C30 and C29 in that order for maximum output. Remove shunt resistor and replace top cap connector.

RF and Oscillator Stages.—Connect signal generator leads to A and E sockets via a suitable dummy aerial, which may consist of a 0.0002 μF capacitor for MW and LW and a 400 Ω resistor for SW. With the gang at maximum or minimum, the pointer should lie behind the horizontal scale border lines at the bottom of the scale.

LW.—Switch set to LW, tune to 1,200 m on scale, feed in a 1,200 m (250 kc/s) signal, and adjust C28, then C24, for maximum output. Feed in an 1,800 m (166.7 kc/s) signal, tune it in, and adjust the core of L7 for maximum output while rocking gang for optimum results.

MW.—Switch set to MW, tune to 210 m on scale, feed in a 210 m (1,429 kc/s) signal, and adjust C27, then C23, for maximum output. Feed in a 500 m (600 kc/s) signal, tune it in, and adjust the core of L7 for maximum output while rocking the gang for optimum results.

SW.—Switch set to SW, tune to 20 m on scale, feed in a 20 m (15 Mc/s) signal, and adjust C22 for maximum output.

There are no tracking adjustments provided for the SW band, but the calibration should be checked at 50 m (6 Mc/s). "Loop" adjustments are made at the works on the end turn of each SW tuning coil, but these should not be disturbed.